



  
**MARREL**  
FASSI GROUP



**MARREL**  
FOREVER HIGHER SINCE 1919

A FASSI GROUP COMPANY



## ABOUT US

Since Marrel's creation, innovation has been part of its DNA. By inventing worldwide-known concepts, like the Ampliroll® hooklift and the Multibenne® skiploader, the company has learnt to stand out.

**From idea to design, development and production: everything is carried out at the Marrel site in Andrézieux Bouthéon (Loire, France).**

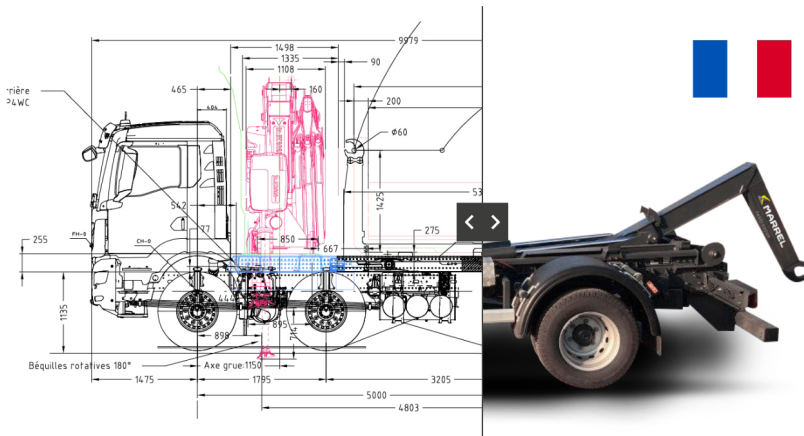

## KEY FIGURES

30.000 M<sup>2</sup> covered area

220 MARREL employees

50 Share (%) of export sales

## International ambitions



The **MARREL - FASSI GROUP** network covers **more than 60 countries** on five continents.

In North America, Marrel has had a subsidiary since 1980: Marrel Corporation.

## A FASSI Group company

Since 2013, Marrel has been part of the Italian FASSI GROUP, world leader in the manufacture of auxiliary cranes on industrial vehicles.

The FASSI Group is made up of seven companies. The cumulative wealth of each company's know-how is the strength of the group, whose watchwords are :



Excellence



Quality



Innovation

**Marrel,  
limitless  
solutions**



## MARREL

### Know-how and expertise in hydraulic systems

Marrel hydraulic cylinders are among the benchmarks on the market, thanks to their great strength, intelligence and versatility.

**They are at the origin of all our equipment... and much more!**







Rear, 2-way & 3-way tipper scissors

## MARREL

### A customized approach to each business

Because each sector has its own specificities, we offer tailor-made equipment for greater handling diversity and optimized performance.



**Waste Management**



**Agriculture**



**Construction**



**Defense & Rescue**



**Municipalities**



MARREL's ambition is always to go higher and further, we have no limits as long as we have the right combination of the right product and the right partner, at the right place.

**Arnaud Thieulin**  
- Marrel CEO





## A constant work in design & innovation

3% of the turnover invested each year

## Quality guaranteed

360° Quality Control & Traceability Certified Management System



## A local & international network

Ongoing support right from the project phase  
Dedicated contacts in each country

An online tool dedicated to our partners



This platform centralizes all commercial and technical documents relating to Marrel equipment and facilitates contact with the various technical departments (warranty, spare parts, assistance, etc.).



## People, the cornerstone of our approach

**Passion, Caring & Ambition** are the values that drive Marrel.  
We make a point of valuing the men and women who, every day, work together hand in hand to progress and break new ground.



# Marrel





Find out more about our solutions & expertise  
**MARREL.COM**



©MARREL

42 avenue de Saint-Etienne  
42161 Andrézieux-Bouthéon Cedex

+33 (0)4 77 36 28 28



A FASSI GROUP COMPANY